

Walraven Strut Rail Beam Clamp

(H 36 05)

to make Strut rail fabrications

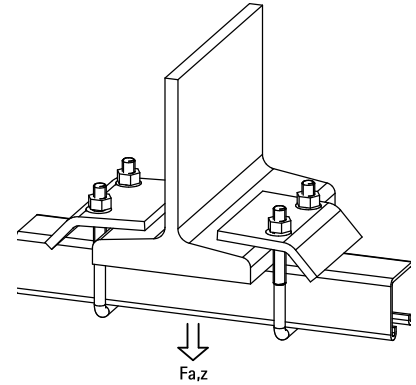

Features and benefits

- for a solid fixing to steel construction
- hot dip galvanized
- without the need for welding or drilling
- always use 2 beam clamps per fixing
- material: steel 1.0332

Part No.	A (mm)	G	L	B (mm)	H (mm)	b (mm)	s (mm)	Lm1 (mm)	SW1 (mm)	T _{inst} (Nm)	For Rail	F _{a,z} (N)	Pack 1
66581711	17.5	M10	69 mm	80	90		5.5	60	17	15	Strut 41x21 + 41x41 + 41x21D	5,700	25
66581721	20.0	M10	69 mm	80	130	44	6.0	75	17	15	Strut 41x62 + 41x82 + 41x41D + DS 5 (41 x 51)	5,700	25

Also available in stainless steel 1.4401 (AISI 316).

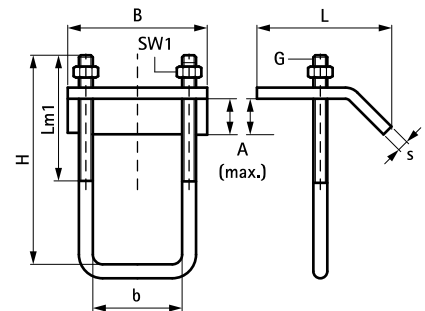

Complementary

Walraven RapidStrut® Channel (pg)
Walraven RapidStrut® Channel DS 5
(BUP1000)

Alternative

Walraven Strut 'Heavy Duty' Beam Clamp